



Development and performance evaluation of a novel dynamic headspace vacuum transfer “In Trap” extraction method for volatile compounds and comparison with headspace solid-phase microextraction and headspace in-tube extraction

Pascal Fuchsmann*, Mireille Tena Stern, Patrick Bischoff, René Badertscher, Katharina Breme¹, Barbara Walther

Agroscope, Schwarzenburgstrasse 161, CH-3003 Berne, Switzerland



ARTICLE INFO

Article history:

Received 25 February 2019

Received in revised form 10 May 2019

Accepted 10 May 2019

Available online 22 May 2019

Keywords:

In-tube extraction

Vacuum-transfer in trap

Reduced pressure sampling

Dairy matrix

Response surface methodology

GC-MS

ABSTRACT

Headspace in-tube extraction (HS-ITEX) and solid phase microextraction (HS-SPME) sampling, followed by gas chromatography-mass spectrometry (GC-MS), are widely used to analyze volatile compounds in various food matrices. While the extraction efficiency of volatile compounds from foodstuffs is crucial for obtaining relevant results, these efficiency of these extraction methods limited by their long extraction times and requirements for large sample quantity. This study reports on the development and application of a new extraction technique based on HS-ITEX hardware, which improves the extraction rate and capacity by operating under reduced pressure, called Dynamic Headspace Vacuum Transfer In-Trap Extraction (DHS-VTT). The results of the study indicate that DHS-VTT improves the extraction of the target compounds. The area of the mass spectrometer signal for each compound can be up to 450 times more intense than the HS-SPME and HS-ITEX techniques performed in the same experimental conditions of extraction temperature and time. DHS-VTT runs in automated mode, making it possible to work with smaller sample quantity and also favors the HS extraction of all volatile compounds. In addition, the necessary modifications to the installation were cheap and the life of an ITEX trap is up to 10 times longer than an SPME fibre.

© 2019 The Authors. Published by Elsevier B.V. This is an open access article under the CC BY-NC-ND license (<http://creativecommons.org/licenses/by-nc-nd/4.0/>).

1. Introduction

In food and flavor analytics, maintaining sample quality is a significant challenge throughout the analytical workflow. A commonly used method for performing sampling of food is by headspace (HS) techniques. Although they are “clean” techniques with respect to the working environment and installations, from our experience they have several drawbacks depending on use such as: Extended heat treatment and extraction time, which can result in artifact formation, change of the molecular structure, and even degradation of the sample. Automated HS-microextraction sampling techniques perform extraction and injection into the gas chromatograph (GC) in a single step, but often result in a discriminative transfer of compounds from the sample into the headspace.

Phase partition coefficients air-water (K_{aw}), sorbent-air (K_{sorb-a}), and sorbent-water (K_{sorb-w}) are the three factors that influence the phase distribution during the extraction for a system in equilibrium [1]. Headspace solid-phase microextraction (HS-SPME) is a cheap, simple and sensitive automated technique for extracting volatile organic compounds (VOCs) from a complex matrix without specific sample preparation. However, our own experience shows that it is very difficult to make robust and accurate analytical methods using HS-SPME. To overcome certain drawbacks of HS-SPME, and add dynamic and automated features at the same time, ‘in-tube extraction’ (ITEX) was introduced in 2006 by CTC Analytics AG (Zwingen, Switzerland). The technique is generally operated using a multifunctional autosampler. HS-ITEX is a solventless dynamic HS microextraction technique derived from several other similar techniques (such as SPME and stir bar sorptive extraction (SBSE)) listed and described by Jochmann et al. [2]. HS-ITEX is a sequential extraction based on progressive dilution and extraction of the headspace on the sample. This extraction technique is related to the multiple headspace extraction method (MHE) [3–6]

* Corresponding author.

E-mail address: pascal.fuchsmann@agroscope.admin.ch (P. Fuchsmann).

¹ Current address: ELSA-Mifroma Group, CH-1470 Estavayer-le-Lac, Switzerland.

Table 1
GC/MS Detection Parameters for the Investigated Compounds and Validation Parameters of the DHS-VIT Method.

Compounds	Retention Time (min)	Quantifier ion (m/z)	Qualifier ion (m/z)	Calibration range ($\mu\text{g L}^{-1}$)	MDL ($\mu\text{g L}^{-1}$)	Mean R^2	RSD (%)	Extraction ratios [%]	
Pentane	5.4	72	43, 57	0.122-31.3	0.27	0.9989	9.4	56.2	Group 1
Hexane	5.9	86	57, 71	0.0305-15.6	0.14	0.9981	8.2	50.0	
Heptane	7.0	100	57, 71	0.0153-7.81	0.17	0.9996	6.8	38.1	
Octane	9.0	114	71, 85	0.0153-7.81	0.11	0.9995	5.5	26.8	
Butanal	11.9	72	44, 57	0.488-15.6	1.12	0.9965	7.3	58.8	
Nonane	12.0	128	85, 99	0.0153-15.6	0.12	0.9994	6.5	23.0	
Butan-2-one	12.8	72	43, 57	0.122-125	0.49	0.9966	7.3	77.8	
3-Methylbutanal	13.3	86	58, 71	0.244-500	0.23	0.9999	4.9	69.3	
Decane	15.4	85	99, 113	0.00763-3.91	0.05	0.9994	7.8	23.1	
Butane-2,3-dione	15.4	86	43	0.488-500	1.71	0.9999	7.8	31.9	
Ethyl butanoate	17.4	116	88, 101	0.00191-1.95	0.01	0.9994	8.4	48.4	
Ethyl 3-methylbutanoate	18.4	85	115, 130	0.00191-3.91	0.00	0.9999	7.4	40.6	
Undecane	18.9	71	113, 127	0.122-15.6	0.26	0.9999	9.8	21.4	Group 2
Hexanal	19.2	82	56, 72	0.244-7.81	2.89	0.9962	14.5	60.4	
Dodecane	22.2	85	127, 141	0.0153-0.977	0.08	0.9999	13.2	23.8	
Heptan-2-one	22.6	114	58, 71	0.0305-1.95	0.30	0.9988	4.7	45.5	
Ethyl hexanoate	24.0	99	88, 144	0.00763-0.488	0.05	0.9992	6.5	36.1	
(E)-Hex-2-enal	24.2	98	69, 83	0.0610-15.6	0.07	0.9991	3.0	72.9	
Tridecane	25.3	85	141, 155	0.0153-31.3	0.04	0.9993	14.0	23.6	
3-Hydroxy-butan-2-one	26.3	45	43, 88	3.91-250	12	0.9987	11.0	18.2	
Hexan-1-ol	27.4	84	56, 69	0.244-7.81	0.13	0.9939	2.2	55.1	
Tetradecane	28.3	198	155, 169	0.0610-31.3	0.26	0.9994	15.5	19.6	
Nonanal	29.1	98	95, 124	0.0610-7.81	0.93	0.9936	33.0	36.4	
Acetic acid	30.6	60	43, 45	31.3-1000	104	0.9986	27.6	50.1	Group 3
Pentadecane	31.0	212	169, 184	0.244-31.3	0.82	0.9997	15.8	15.5	
Propanoic acid	32.9	74	57, 73	31.3-1000	53	0.9988	28.6	52.1	
Hexadecane	33.6	226	197, 183	0.244-62.5	4.6	0.9997	15.5	37.0	
2-Methylpropanoic acid	34.0	88	43, 73	0.244-125	0.19	0.9994	14.7	15.4	
Undecan-2-one	34.5	170	85, 112	0.0610-125	0.15	0.9981	9.0	33.5	
Butanoic acid	35.1	73	60, 88	0.488-125	0.74	0.9990	6.1	31.6	
Ethyl decanoate	35.2	101	143, 115	0.0153-1.95	0.06	0.9983	8.1	31.0	
3-Methylbutanoic acid	36.2	87	60, 69	0.244-62.5	1.22	0.9987	14.0	17.7	
2-Phenylacetaldehyde	36.5	120	91, 92	0.0153-15.6	0.20	0.9990	12.8	43.2	
γ -Butyrolactone	36.6	86	42	7.81-1000	72	0.9898	NA	10.7	
(2E,4E)-Nona-2,4-dienal	37.6	138	138, 95	0.122-125	0.24	0.9991	28.4	40.7	
4-Methylpentanoic acid	39.3	83	101, 73	0.122-62.5	3.12	0.9968	10.3	18.5	
Hexanoic acid	40.2	87	87, 73	7.81-1000	64	0.9992	20.4	17.1	
2-Phenylethanol	42.4	122	91, 92	0.00763-15.6	0.03	0.9997	6.9	45.5	
Octanoic acid	45.3	101	115, 144	15.6-1000	59	0.9942	28.6	3.1	
δ -decalactone	52.2	99	114, 134	0.0305-62.5	0.13	0.9971	13.1	39.9	
Decanoic acid	52.8	73	129, 143	15.6-1000	65	0.9985	NA	3.6	
(Z)-6-Dodecen-4-olide	62.4	85	96, 136	0.00381-0.244	0.1	0.9987	43.8	25.3	
Dodecanoic acid	65.3	60	96, 136	31.3-1000	43	0.9901	9.4	1.0	

NA: Not available.

and provides an interesting alternative to HS-SPME; it has been used to extract numerous volatile chemical compounds from various matrices, including food, plants, pollutants, and biological fluids [2,7–10]. Another similar technique developed by SmartNose SA (Marin-Epagnier, Switzerland), Inside Needle Dynamic Extraction (INDEX), uses the same concept of extraction as HS-ITEX, and further HS extraction techniques have been extensively reviewed in the literature [11]. Improvement of the different parameters of the HS-ITEX is required to achieve adequate signals through optimized extraction and thermal desorption [7,12]. The HS-ITEX key parameters are the nature of the sorbent material, the number of strokes (according to the literature: between 20 and 120 [2,3,8,10,13]), the extraction speed, the desorption speed, the sample, the trap and syringe temperature, and the headspace volume extracted. Many commercial extraction polymers were evaluated by Laaks et al. [14] and are available on the market. The trap can also be filled with noncommercial sorbents, such as multivalled carbon nanotubes or polystyrene-divinylbenzene [1,9,15]. The choice of the sorbent material is made based on the target molecule to be extracted. An innovative technique developed by Barajas et al. [16] also makes it possible to evaluate and characterize sorbents by inverse gas chromatography column.

Depending on the matrix and desired results, improving different parameters may be required, making the optimization of the technology very complex compared to HS-SPME [17].

The goal of this study was to develop and optimize a reproducible, robust, and sensitive extraction method that reduces the drawbacks of traditional headspace extraction techniques. A new technique is proposed that combines features of HS-ITEX and principles of vacuum-HS-SPME and vacuum distillation coupled with gas chromatography [18–21]: Dynamic Headspace Vacuum Transfer In Trap Extraction (DHS-VTT). The new method aimed to avoid strokes, the limited injection volume and provide dynamic extraction under vacuum conditions. Several publications have reported a significant improvement of the extraction under reduced-pressure using so-called vacuum HS-SPME [22–24]. However, this technique can up to now only be used manually. To address this lack, the current method was designed to function with an automatic mode.

This paper discusses the development and application of our new extraction technique, DHS-VTT using a model of an artificially constructed matrix (ACM). We assess the method's sensitivity, and its suitability for the qualitative and quantitative analysis of a broad range of volatile compounds, small sample volume, and large sample series. The suitability and efficiency of DHS-VTT were verified by comparison to HS-SPME and HS-ITEX, as well as analysis of ACM and plain yoghurt using parameters commonly found in the literature for HS-ITEX and HS-SPME [25].

2. Experimental

2.1. Materials and methods

2.1.1. Chemicals and samples

The relevant chemical compounds were purchased from Sigma-Aldrich Chemie GmbH (Buchs, Switzerland), R.C. Treatt & Co. Ltd (Suffolk, United Kingdom), and Caesar & Loretz GmbH (Hilden, Germany): Hexan-1-ol (Aldrich 471402), 2-Phenylethanol (Aldrich 77861), Butan-2-one (Aldrich 360473), Butane-2,3-dione (Aldrich B85307), 3-Hydroxybutan-2-one (Aldrich W200808), Heptan-2-one (Aldrich W254401), Undecan-2-one (Aldrich W309311), Ethyl butanoate (Aldrich W242705), Ethyl 3-methylbutanoate (Aldrich W246301), Ethyl hexanoate (Aldrich W242906), Ethyl decanoate (Aldrich W243205), γ -Butyrolactone (Aldrich 90970), δ -Decalactone (Aldrich W236101), (Z)-6-Dodecen-4-olide (R.C. Treatt 62185), Butanal (Aldrich W221902), 3-Methylbutanal

Table 2

Two-level full factorial design of experiment for the method validation.

Design	Sample temperature [°C]	Extraction time [min]
1	37	13
2	37	52
3	73	13
4	73	52
5	30	33
6	80	33
7	55	5
8	55	60
9	55	33
10	55	33
11	55	33
12	55	33

Changed parameters: sample temperature (37°C–80°C) and extraction time (5–60 min).

(Aldrich 146455), Hexanal (Aldrich 115606), (E)-Hex-2-enal (Aldrich W256005), 2-Phenylacetaldehyde (Aldrich W287407), Nonanal (Aldrich W278203), (2E,4E)-Nona-2,4-dienal (Aldrich W321206), Acetic acid 99.7% (Aldrich 695092), Propanoic acid (Aldrich P1386), 2-Methylpropanoic acid (Aldrich W222208), Butanoic acid (Aldrich W222119), 3-Methylbutanoic acid (Aldrich W310212), 4-Methylpentanoic acid (Aldrich W346306), Hexanoic acid (Aldrich W255904), Octanoic acid (Aldrich W279927), Decanoic acid (Aldrich W+236411), Dodecanoic acid (Aldrich 61609), Pentane (Aldrich 236705), Hexane (Aldrich 296090), Heptane (Aldrich 246654), Octane (Aldrich 296988), Nonane (Aldrich 296821), Decane (Aldrich 457116), Undecane (Aldrich W510505), Dodecane (Aldrich 297879), Tridecane (Aldrich T57401), Tetradecane (Aldrich 172456), Pentadecane (Aldrich P3406), Hexadecane (Aldrich 296317), Polyethyleneglycol 200 (Aldrich P3015), Miglyol 812 (Caesar 3274), Sodium chloride > 99% (Aldrich S9888), and phosphoric acid (Aldrich W290017). Plain yoghurt (3.5% fat) was purchased from a local supermarket.

2.1.2. ITEX sorbent materials

ITEX traps filled with Tenax[®] TA (TTA), Tenax[®] GR (TGR), Cabosieve S III (CSIII), and Cabosieve S III/Tenax[®] TA (CSIII/TTA) were purchased from BGB Analytik AG, Boeckten, Switzerland.

2.1.3. Artificially constructed matrix (ACM)

To develop and optimize the DHS-VTT technique, a stable sample was prepared using 43 target compounds representing chemical families that are often present in dairy matrices (alcohols, ketones, aldehydes, alkanes, carboxylic acids, and lactones; see Table 1), all diluted to a concentration of 10 mg L⁻¹ in 20 mL of polyethylene glycol 200. The alkanes were separately diluted in Miglyol[®] 812 at the same concentration. Polyethylene glycol 200 was chosen because it is a good solvent for the selected compounds and does not react with the volatile compounds present in the ACM. The compounds that are not soluble in polyethylene glycol 200 (the alkanes) were dissolved in Miglyol[®] 812 which also simulates the lipid part of a dairy matrix. These mixtures were stored at -40°C until analysis.

2.1.4. Sample preparation

ACM standard solutions (25 μ L of each standard) was diluted with H₃PO₄ 4% in deionized water at pH 1.3 (total sample volume of two millilitres) and placed in 20 mL HS vials (Interchim, Montluçon, France). The acidification of the sample helps to promote the volatility of carboxylic acids. Phosphoric acid is not volatile and will not interfere in the analyses either. The vials were hermetically sealed using a blue silicone/Teflon septum (Interchim). Calibration curves were made by diluting the stock solution by a factor of two for a minimum of seven points. To facilitate data processing, the 43

Table 3
Comparison between DHS-VTT with different sorbent materials, HS-ITEX TTA and HS-SPME for the investigated compounds.

	HS-ITEX TTA	HS-SPME DVB/CAR/PDMS 1cm	DHS-VTT CSIII	DHS-VTT TGR	DHS-VTT TTA	DHS-VTT TTA/CSIII
	70 Strokes at 55°C	ext. time 30 min at 55°C	ext. time 30min at 55°C	ext. time 30min at 55°C	ext. time 30min at 55°C	ext. time 30min at 55°C
Pentane	1.7E+05	5.1E+04	7.2E+04	7.0E+02	2.6E+01	5.1E+04
Hexane	3.2E+05	3.0E+05	4.6E+05	1.9E+04	5.4E+03	5.8E+05
Heptane	4.9E+05	6.9E+05	1.7E+06	1.3E+06	5.2E+05	2.4E+06
Octane	4.2E+05	1.0E+06	4.3E+06	4.6E+06	5.2E+06	5.4E+06
Butanal	8.6E+05	2.3E+05	1.2E+06	2.7E+05	3.6E+05	9.2E+05
Nonane	5.3E+04	7.3E+05	1.4E+06	1.5E+06	3.2E+06	2.9E+06
Butan-2-one	1.1E+06	1.2E+06	3.2E+06	3.1E+05	2.3E+04	4.1E+06
3-Methylbutanal	1.0E+05	1.1E+05	1.2E+05	8.6E+04	2.5E+04	1.2E+05
Decane	2.1E+04	1.3E+05	9.2E+05	1.1E+06	3.4E+06	3.3E+06
Butane-2,3-dione	2.0E+05	2.3E+05	1.1E+06	4.7E+05	6.6E+05	1.4E+06
Ethyl butanoate	2.8E+04	1.8E+05	7.4E+05	6.2E+05	1.1E+06	1.0E+06
Ethyl 3-methylbutanoate	2.2E+05	7.7E+05	1.1E+07	9.2E+06	1.5E+07	1.4E+07
Undecane	1.2E+04	3.9E+04	3.8E+05	6.7E+05	2.7E+06	2.8E+06
Hexanal	1.6E+05	5.7E+05	8.9E+05	1.8E+06	2.6E+06	1.8E+06
Dodecane	7.0E+03	4.1E+04	1.0E+05	3.8E+05	1.6E+06	1.8E+06
Heptan-2-one	2.6E+04	2.7E+05	1.5E+06	1.5E+06	3.1E+06	3.2E+06
Ethyl hexanoate	1.8E+04	5.3E+05	1.1E+06	1.4E+06	2.6E+06	2.7E+06
(E)-Hex-2-enal	3.8E+04	2.9E+05	5.3E+06	4.2E+06	1.0E+07	1.0E+07
Tridecane	3.4E+03	2.0E+04	2.3E+04	2.2E+05	8.3E+05	1.0E+06
3-Hydroxy-butan-2-one	0.0E+00	1.4E+03	1.6E+04	6.8E+04	1.3E+05	7.4E+04
Hexan-1-ol	1.9E+04	1.5E+05	8.9E+05	6.7E+05	1.3E+06	1.2E+06
Tetradecane	6.4E+02	9.4E+03	5.6E+03	1.3E+05	3.9E+05	5.0E+05
Nonanal	1.4E+04	1.1E+05	3.2E+05	2.2E+06	2.8E+06	3.0E+06
Acetic acid	0.0E+00	1.1E+05	7.2E+05	1.6E+06	6.4E+05	2.4E+06
Pentadecane	0.0E+00	5.7E+03	2.9E+03	6.5E+04	1.7E+05	2.3E+05
Propanoic acid	1.5E+04	1.1E+05	1.6E+06	2.3E+06	2.4E+06	5.0E+06
Hexadecane	0.0E+00	6.8E+04	2.0E+06	2.9E+06	3.3E+06	4.2E+06
2-Methylpropanoic acid	0.0E+00	1.7E+03	3.4E+03	3.9E+04	7.1E+04	1.1E+05
Undecan-2-one	3.8E+02	4.0E+03	6.5E+04	3.9E+05	4.6E+05	8.0E+05
Butanoic acid	2.1E+04	5.0E+05	8.2E+06	1.0E+07	1.6E+07	2.4E+07
Ethyl decanoate	1.6E+03	1.7E+04	7.2E+04	7.3E+05	6.4E+05	1.4E+06
3-Methylbutanoic acid	1.9E+04	6.4E+04	1.8E+05	1.6E+06	3.2E+06	2.4E+06
2-Phenylacetaldehyde	0.0E+00	1.8E+04	2.8E+05	3.2E+05	3.2E+05	3.3E+05
γ-Butyrolactone	1.8E+03	1.4E+05	4.9E+06	6.3E+06	9.4E+06	1.1E+07
(2E,4E)-Nona-2,4-dienal	0.0E+00	3.5E+03	7.2E+04	5.9E+05	1.1E+06	1.6E+06
4-Methylpentanoic acid	0.0E+00	4.0E+04	5.6E+05	1.3E+06	2.5E+06	3.4E+06
Hexanoic acid	0.0E+00	6.9E+04	5.5E+05	1.2E+06	2.8E+06	3.7E+06
2-Phenylethanol	0.0E+00	2.2E+05	2.8E+06	3.8E+06	7.1E+06	7.9E+06
Octanoic acid	6.1E+03	5.8E+04	2.1E+04	2.6E+05	3.9E+05	5.3E+05
δ-decalactone	0.0E+00	0.0E+00	5.5E+03	1.3E+04	1.1E+04	5.2E+04
Decanoic acid	7.7E+02	8.8E+03	1.8E+04	8.5E+04	3.6E+04	4.7E+04
(Z)-6-Dodecen-4-olide	0.0E+00	0.0E+00	6.1E+03	1.3E+04	1.4E+04	1.7E+04
Dodecanoic acid	0.0E+00	0.0E+00	1.3E+04	8.0E+03	4.0E+03	4.4E+03

The values represented are the total ion count (TIC) [-] for the MS signal

compounds were classified into three groups, based on their molecular weight and volatility as well as elution time: group 1, spanning over C5 and C10; group 2, spanning over the first peak right after C10 and C13; and group 3, spanning over the first peak right after C13 and C20 (Tables 1 and 3).

For real dairy analyses, two millilitres of homogenized plain yoghurt were placed in 20 mL HS vials (Interchim) and they were hermetically sealed using a blue silicone/Teflon septum (Interchim).

2.1.5. Modification of the gas distribution block

The original two-way aluminum gas distribution block of the autosampler MPS2 (Gerstel, Sursee, Switzerland) was replaced by a three-way block printed on a 3D Touch Pegasus printer (Full Spectrum Laser, Las Vegas, US) with “Universal Clear Resin” (Full spectrum Laser) (Fig. 1). The polymer was solidified using UV exposure after printing. This modification makes it possible to switch the solenoid valve between the vacuum pump and the inert gas to extract volatile compounds from the sample with the vacuum and desorb them into the injector using an inert gas flow.

2.1.6. Pressure measurement

In order to verify the hermeticity of the vial, a pressure of 10 mbar was applied in an empty vial using a vacuum pump Buchi V-300 equipped with a pressure control interface I-300 (Büchi, Flawil, Switzerland). The vial was connected to a pressure sensor PAA-27 (Keller, Winterthur, Switzerland) and a measuring device Almemo 2590 (Ahlborn, Holzkirchen, Germany). The pump was then stopped and the signal was recorded simultaneously in a csv file and processed with Excel.

Evaluation of the pressure in the vial during HS-ITEX and DHS-VTT extraction was carried out using the same equipment as described above. The measuring device was connected to a needle which pierces the septum of the vials at the same time that the extraction was performed. Instrumentation for GC–MS analysis

The analyses were completed using an MPS2 autosampler (Gerstel) on an Agilent 7890B GC system coupled to an Agilent 5977A mass selective detector (MSD) (Agilent Technology, Santa Clara, CA, USA). The headspace was extracted according to the experimental design (Table 2). Bound volatiles were desorbed in a PTV of type CIS 4 (Gerstel). Volatile compounds were separated on a TRB-FFAP fused silica capillary column (100% PEG with nitroterephthalic acid, bonded and crosslinked, 60 m × 0.32 mm × 1.0 μm film; Teknokroma, Barcelona, Spain) with helium as the carrier gas at a constant flow of 2.5 mL min⁻¹ (30 cm sec⁻¹).

The oven temperature program was as follows: five minutes at 40 °C, then heated to 220 °C at a rate of 5 °C min⁻¹, with a final hold time of 34 min to make a total run time of 75 min. The MS settings were as follows: the transfer line at 230 °C, the source temperature at 230 °C, the compounds monitored in SCAN mode between 29 amu and 250 amu without solvent delay, and in SIM mode for the method detection limits (MDLs) and the calibration curves. The autosampler was controlled using the Cycle Composer V. 1.5.4 (CTC Analytics, Zwingen, Switzerland) and the PTV injector with Maestro1 software V.1.4.8.14/3.5 (Gerstel). The detector response signals were integrated using Masshunter quantitative analysis software version B.08.00 (Agilent). The NIST/EPA/NIH mass spectral library (NIST14) version 2.2 (NIST, Gaithersburg, MD, USA) was used for peak identification.

2.2. Headspace in-tube extraction (HS-ITEX)

The ITEX-2 option (Brechtbühler, Schlieren, Switzerland) was used on the MPS2 autosampler. The headspace was extracted using a TTA trap with 70 extraction strokes (volume of 1.3 mL/stroke, extraction flow rate of 100 μL s⁻¹). ACM and yoghurt samples were

not conditioned for this experiment. The syringe temperature was fixed at 100 °C, the ITEX trap at 35 °C, and the sample at 55 °C. The bound volatiles were desorbed from the sorbent material at 240 °C in a CIS4 injector equipped with a glass liner filled with TTA at 10 °C. A volume of 1.3 mL was transferred into the injector at a desorption flow rate of 100 μL s⁻¹, after having waited 30 s (plunger down) in the vent mode (50 mL min⁻¹, set pressure: 0 kPa). The injector was then heated at a rate of 12 °C s⁻¹ to 240 °C. The purge flow to split vent was set at 300 mL min⁻¹ after 5 min. After injection, the ITEX needle was reconditioned according to the supplier's temperature recommendation for 15 min under a nitrogen flow of 220 mL min⁻¹ (measured at 35 °C).

2.2.1. Headspace solid-phase microextraction (HS-SPME)

To obtain a representative evaluation of the VOCs of the samples, the VOCs were extracted using a 1 cm 50/30 μm divinylbenzene/carboxen/polydimethylsiloxane (DVB/CAR/PDMS) StableFlex fibre (Supelco, Bellefonte, PA, USA). The fibre was conditioned according to the supplier's recommendations (270 °C for 60 min). ACM and yoghurt samples were not conditioned for this experiment. The sample headspace was extracted for 30 min at 55 °C with an agitation rate of 250 rpm. The bound volatiles were desorbed for 60 s at 240 °C in the injector, which was in the splitless mode for 60 s before the split valve was opened (split flow = 80 mL min⁻¹) [25].

2.2.2. Dynamic headspace vacuum transfer in trap extraction (DHS-VTT)

DHS-VTT requires the same equipment as HS-SPME and HS-ITEX methods. A vacuum pump with pressure control interface and the new gas distribution block complete the installation (Fig. 2 A).

A piece of cleaned swab Topper® 8 10 × 10 cm (Systagenix, North Yorkshire, United Kingdom) was added to the vial to avoid boiling and foaming. The syringe temperature was fixed at 100 °C, the ITEX trap at 35 °C, and the sample according to the experimental design (Table 2). The extraction takes place as illustrated (Fig. 2B). Sample conditioning: ACM and yoghurt samples were not conditioned for this experiment. Extraction: The trap pierces the septum and the plunger rises to the upper position. When the plunger is in the upper position, the HS was extracted under continuous reduced pressure using a vacuum pump Buchi V-300 equipped with a pressure control interface I-300 (Büchi) and the gas distribution block according to the experimental design (Table 2) without agitation. Drying: The trap was then removed from the sample and the solenoid valve switches to nitrogen. Sorbent and syringe were dried under a nitrogen stream for 17 min at 220 mL min⁻¹ [26]. Desorption: The trap was then introduced into the PTV injector and the bound volatiles were desorbed from the sorbent for 120 s with a nitrogen flow of 220 mL min⁻¹ (fixed at 35 °C) at 240 °C. The PTV injector was in the vent mode at 50 mL min⁻¹ and 0 kPa for 120 s. The injector was equipped with a glass liner filled with TTA and cooled with liquid nitrogen at 10 °C. The trap was removed from the injector and the injector was then heated, at a rate of 12 °C s⁻¹, to 240 °C. The purge flow to split vent was set at 300 mL min⁻¹ after 5 min. Trap Cleaning: The reconditioning of the trap was achieved in the same way as for the HS-ITEX method by circulating a flow of nitrogen through the trap at the recommended temperature with the plunger in the upper position.

2.3. Experimental design and statistics

To optimize experimental parameters, a two-level full factorial design of the experiment was performed. Only the sample temperature and the time of extraction were investigated because these are the parameters that have the most easily modifiable and have the greatest impact on the extraction of volatile compounds. The temperature of the trap should be kept as low as possible

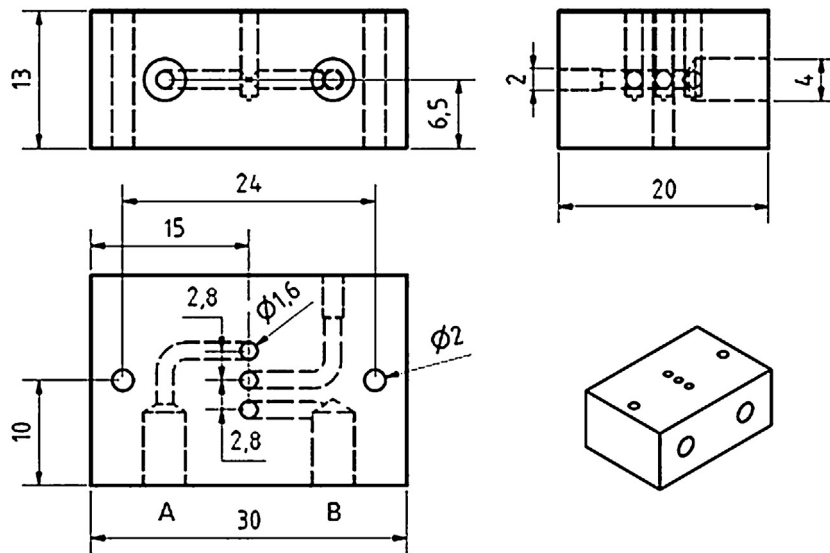

Fig. 1. Design of the modification of the gas distribution block in polymer (dimension in mm). The block was designed with three ways, one for the nitrogen supply (A), one for the vacuum (B), and the last way was directly connected to the autosampler.

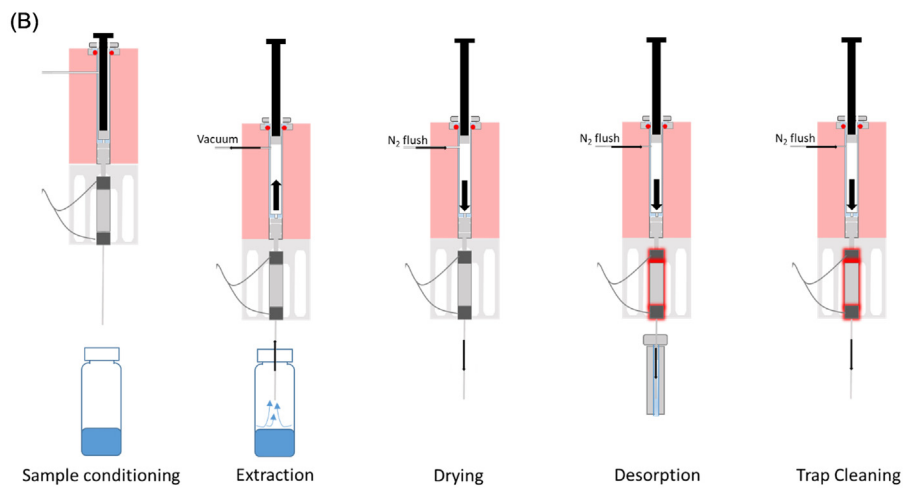
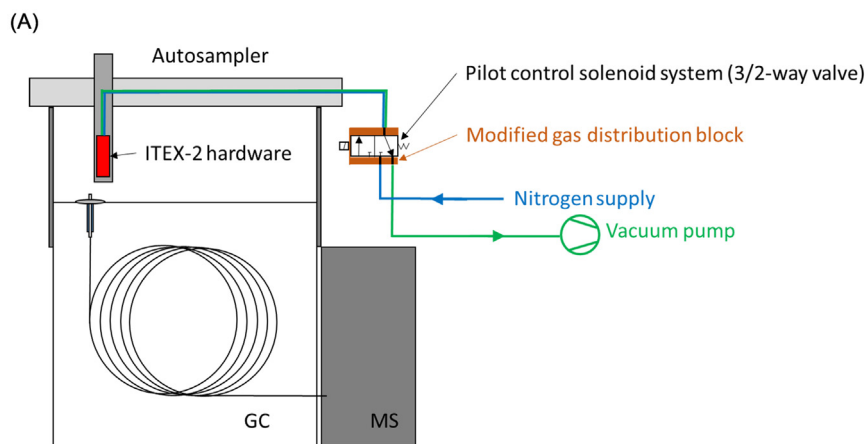

Fig. 2. (A) Diagram of the GC–MS instrument with the autosampler (MPS2) and ITEX-2 hardware. Connection of the original nitrogen line to the new distribution block (in orange) and the solenoid valve. The vacuum and nitrogen lines are coloured green and blue respectively. (B) Stages of the extraction process using the DHS-VTT method. Sample conditioning, extraction, drying, desorption and trap cleaning steps.

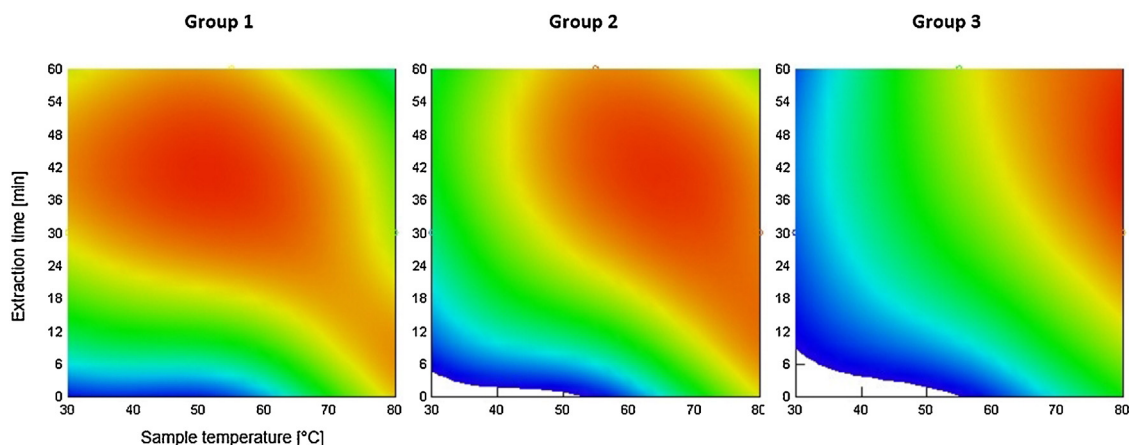

Fig. 3. Parameter optimization according to the experimental design for DHS-VTT (TTA/CSIII). X-Axis: Sample temperature [°C]. Y-Axis: Extraction time [min]. Z-Axis: Total ion count normalized [-]. The color variations represent blue for a low signal and red for a high signal.

(within the constraints of the instrument specifications and the laboratory environment) and the syringe temperature kept at 100 °C to exclude water condensation during the extraction. Three centrally composed DHS-VTT experimental plans were developed. The respective results were evaluated and presented to show the areas of effect. Mosaic plots (Fig. 3), which can be interpreted using color, were chosen for the present work, and each peak area of effect was smoothed squaredly (smoothing method). In the plots, the intensity of the peak area observed is displayed in color, from blue (no signal), through dark and light green, yellow-orange, and, finally, to red, the largest and most intense peak area, which is equivalent to the maximal signal. The mean values of these measurement ranges were the center of the Central Composite design. The remaining levels were placed radially around the center in a 2×2^2 experiment, which corresponds geometrically to two squares, rotated by 45° in the plane around their center. This design allows for the influence of five levels per parameter. Height points are distributed around the center at the same relative distance. In total, 12 measuring points are made, the center point for the variability being measured four times.

3. Results and discussion

3.1. Extraction parameters

3.1.1. Pressure in the headspace

The effectiveness of blue silicone/Teflon septum in the hermeticity of vials has shown that the pressure remained stable for a period of 10 min after the pump was stopped and thus can be considered as sufficiently effective for the analyses (results not shown).

The pressure measurements made during the extraction according to the HS-ITEX method show that the extractions were carried out above atmospheric pressure due to air expanding in the vial during extraction when it was heated. The sample was prepared at atmospheric pressure before extraction then placed in the autosampler cooling device (4 °C). The pressure immediately decreased due to the volume contraction of the air in the vials. Then the vial was placed in the heating agitator (55 °C), and the pressure increased above the atmospheric pressure (Fig. 4, red signal). Throughout extraction, the high pressure remained constant. As a result, the rate of evaporation of the compounds decreases and the extraction efficiency of volatile compounds was thus lower [27].

This phenomenon was similar during an HS-SPME extraction without the strokes effect. With the change of the gas distribution block, it was possible to automate the extraction at reduced pressure in the vial throughout the extraction (Fig. 4, green signal). The

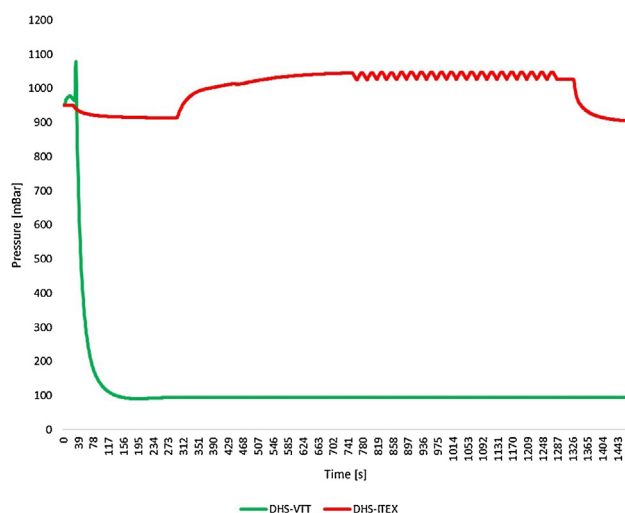

Fig. 4. The pressure inside the vials during extraction using HS-ITEX (red) and DHS-VTT (green) method at set pressure: 100 mbar.

vacuum obtained in the vials greatly influenced the extraction of volatile compounds [22]. A pressure above 100 mbar was no longer sufficient for extracting the compounds efficiently (Fig. 5). Reduced pressure accelerated the release of the volatile compound in the headspace, but also has an impact on the efficiency of the sorbent. Low pressure over a long period of time desorbs the most volatile compounds of the sorbent. Consequently, it was necessary to determine the optimal conditions for achieving a suitable compromise between the pressure in the vial and the extraction rate. The pressure effects depended on the volatility of the molecules. The highly volatile compounds as the pentane were better retained on the polymer when the pressure in the vial was not less than about 50 mbar (data not shown), while other volatile compounds were more easily extracted at the lowest possible pressure. The effect of the reduced pressure during extraction caused an issue already known from the purge and trap technology—the accumulation of water vapor in the system (needle, syringe, tubes) and artifact formation [12,26]. To avoid this, the trap and the syringe were dried under a nitrogen flow for a time determined prior to injection into the injector.

3.1.2. Sample volume and HS volume

Tests were conducted using sample volumes of 0.5, 1, 2 and 4 mL in 20 mL HS vials. The DHS-VTT parameters were the same

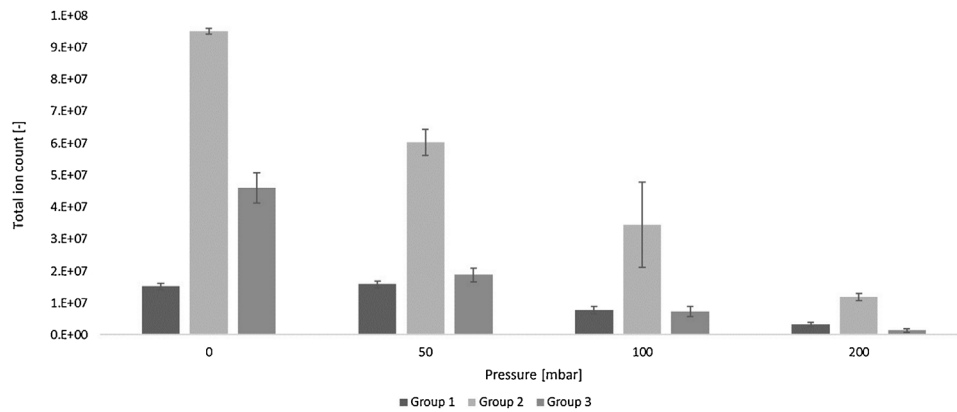

Fig. 5. The sum of the peak areas of the 43 target compounds divided into three groups (Y-Axis: Total ion count) as a function of the pressure in the vials, expressed in mbar (set pressure) (X-Axis).

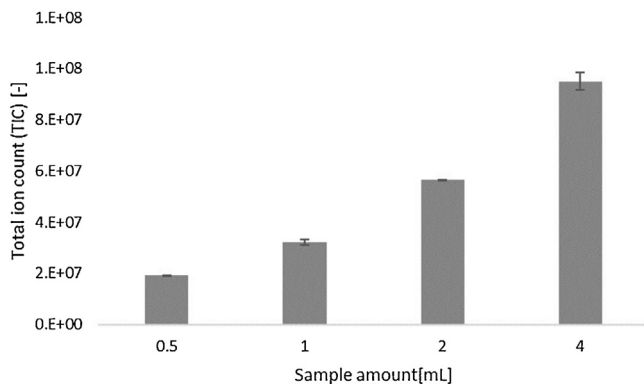

Fig. 6. Influence of the sample amount on the total ion count (TIC) MS signal of the target compounds.

for each test. The amount of the sample, and, consequently, the number of volatile molecules available in the vials influenced the extraction. When the amount of the sample doubled, the total signal increased proportionally by a factor of 1.7 for a given extraction time (Fig. 6). This demonstrates that the extraction capacity of the

trap was not reached, allowing for quantitative studies using a 2 mL sample [28,29].

3.1.3. PTV injector temperature

Low temperature in the liner had a positive impact on the recovery of volatile compounds. The change from 10 °C to –50 °C does not show a significant improvement in recovery of volatile compounds for groups 2 and 3. For reasons of cost and efficiency, we used a temperature of 10 °C for the PTV (Fig. 7).

3.1.4. Sample temperature and extraction time

The effect of the sample temperature was evaluated for temperatures between 30 and 80 °C using the described experimental design (Table 2). Increased temperature led to an increase in the signal for all compounds due to a higher partitioning of compounds from the aqueous phase to the headspace [1]. The higher the temperature, the higher the extraction efficacy for the less volatile compounds. At certain high temperatures, the compounds degraded and tended to contaminate the autosampler, i.e., water vapor condensed in the trap, the syringe, and the autosampler tubes. Despite the hydrophobic nature of TTA, an accumulation of water in the trap could result in the problem of injecting water droplets into the GC with the injection of the compounds [26].

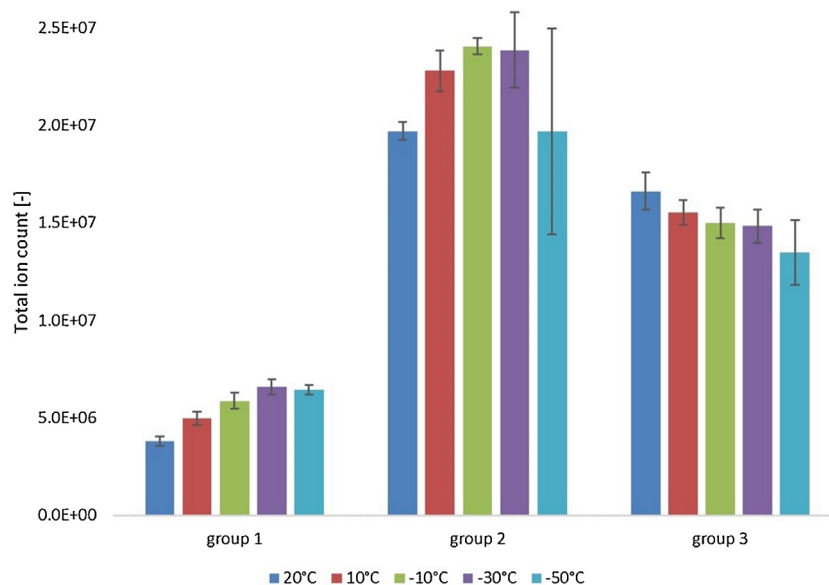

Fig. 7. Influence of the PTV injector temperature on the recovery of the investigated compounds after injection. The injector temperature was tested between 20 °C and –50 °C.

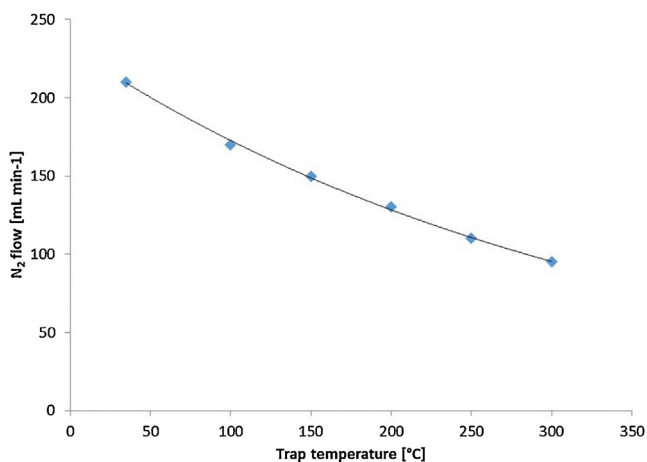

Fig. 8. Influence of the thermodesorption temperature on the nitrogen flow inside the ITEX trap.

With a reduced pressure in the vials, we observed that the extraction rate accelerated. For the most volatile compounds, a prolonged extraction time had a negative effect on the recovery of the molecules [1]. Indeed, when extraction time was too long, the most volatile compounds were released from the sorbent. For the majority of the molecules studied in ACM, the results of the experiment showed an optimal time of 30 min at 55 °C. The extraction parameters can be adapted according to the molecules to be studied (Fig. 3).

3.1.5. Nitrogen flow desorption

The nitrogen flow was optimized to 220 mL·min⁻¹ at 35 °C to allow for proper desorption of the compounds fixed to the polymer and extraction to counteract against the pressure into the injector during desorption. An exponential decrease in the nitrogen flow rate was noted when the temperature of the trap increased (Fig. 8). A too-high flow (>300 mL·min⁻¹) sometimes clogged the trap by sealing the sorbent material.

3.2. Comparison of HS-SPME, HS-ITEX, and DHS-VTT

The results indicate that DHS-VTT clearly improves the extraction of volatile compounds from a complex matrix as the ACM (Table 3). The peak area can be increased by a factor of 450 for some compounds in comparison with using the HS-SPME method. In comparison, HS-SPME extraction, widely used in common headspace applications, achieves lower efficiency for all compounds measured under the same temperature and extraction time conditions. The DHS-VTT technique enriches the gas phase rapidly by limiting the matrix effects because of the reduced pressure in the vial. Moreover, the conventional HS-ITEX method cannot extract the least volatile compounds. The headspace is rapidly in a stable state in HS-ITEX, and the strokes are inadequate to extract more volatile compounds. The choice of polymer in the DHS-VTT extraction trap was also very important for optimal extraction. The best compromise for the 43 compounds used in this study was the Tenax TA/Carbosieve SIII blend.

The profiles of the volatile fraction obtained for a plain yoghurt using the DHS-VTT, HS-ITEX, and HS-SPME extraction methods show that the DHS-VTT method was suitable for this type of sample (Fig. 9). The analyses performed on the yoghurt confirm the results obtained with the ACM. The HS-ITEX method was effective for the extraction of highly volatile compounds such as acetaldehyde but did not extract heavier compounds under the described conditions. With the HS-SPME all compounds except the decanoic acid could be identified. However, the signals were much weaker than with the DHS-VTT method. The surface area of the peaks was higher with DHS-VTT and a higher number of compounds could be detected in SCAN mode using this method.

3.3. Performance evaluation of DHS-VTT

Performance evaluation was carried out by determining the following parameters:

- The linearity (R^2) of the method was evaluated by measuring the target compounds in six different concentrations in the ACM corresponding to the ranks commonly found in dairy matrices.

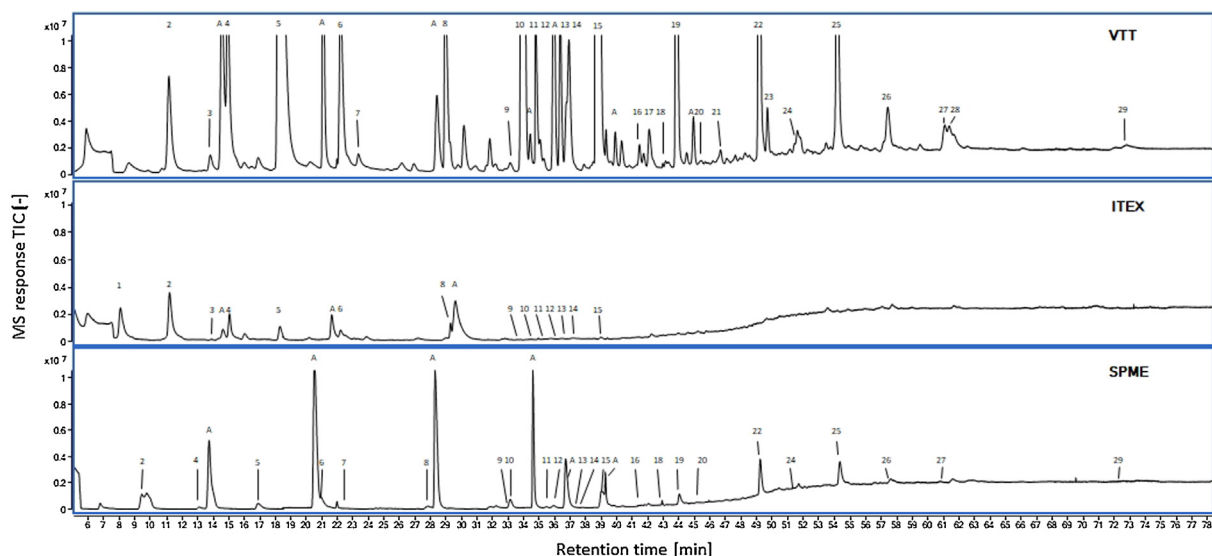

Fig. 9. Chromatograms corresponding the volatile fraction of plain yoghurt extracted by DHS-VTT, HS-ITEX and HS-SPME methods. The chromatographic conditions were given in Section 2.2 Instrumentation for GC–MS analysis (sample temperature 55 °C, extraction time 30 min). Peak numbers correspond to : 1:Acetaldehyde, 2:Acetone, 3:Ethylacetate, 4:Butan-2-one, 5:Butane-2,3-dione, 6:Hexanal, 7:Hexanoic acid, 8:Heptan-2-one, 9:Octanal, 10:3-Hydroxybutan-2-one, 11:2-Methylpentan-3-ol, 12:2-Hydroxy-3-pentanone, 13:Nonan-2-one, 14:Nonanal, 15:Acetic acid, 16:Propanoic acid, 17:2-Methylpropanoic acid, 18:Undecan-2-one, 19:Butanoic acid, 20:2-Phenylacetaldehyde, 21:Decanoic acid, 22:Hexanoic acid, 23: 6,10-dimethylundeca-5,9-dien-2-one, 24:2-Phenylethanol, 25:Octanoic acid, 26:Nonanoic acid, 27: δ -Decalactone, 28:Decanoic acid, 29: δ -Dodecalactone. A, Artifact.

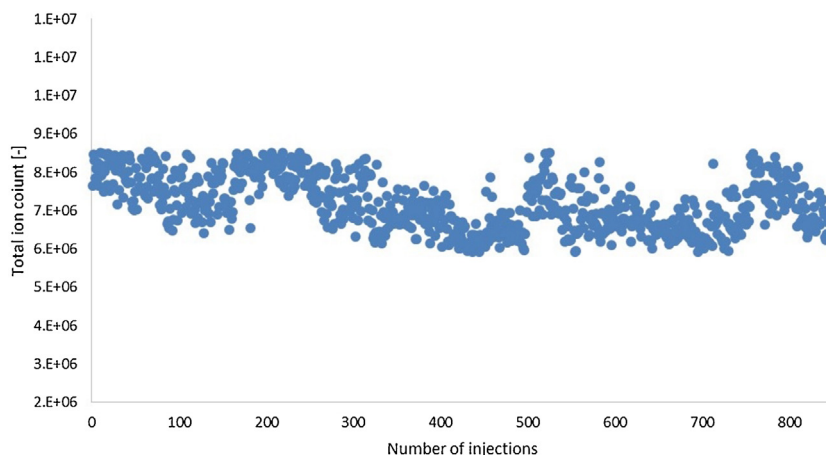

Fig. 10. 850 injections of the ACM sample over two weeks in DHS-VTT. Y-axis: Sum of the peak areas of the 43 molecules selected. Standard deviation 9.6%.

The R^2 was approximately 0.99 +/- for all compounds except for γ -butyrolactone with 0.98.

- The MDL of the target molecules was estimated according to the US Environmental Protection Agency procedure and Eq. (1):

$$\text{MDL} = t_{(N-1, 1-\alpha=0.99)} \times S_c \quad (1)$$

- where t is the student's t value with a confidence level of 99% and six degrees of freedom and S_c the standard deviation of seven replicates at a concentration level featuring a signal-to-noise ratio (S/N) of three to one. The MDLs measured for alkanes ranged from $0.036 \mu\text{g L}^{-1}$ to $0.822 \mu\text{g L}^{-1}$, for esters from $0.003 \mu\text{g L}^{-1}$ to $0.071 \mu\text{g L}^{-1}$, for aldehydes from $0.050 \mu\text{g L}^{-1}$ to $2.89 \mu\text{g L}^{-1}$, for ketones from $0.145 \mu\text{g L}^{-1}$ to $11.9 \mu\text{g L}^{-1}$, for lactones from $0.130 \mu\text{g L}^{-1}$ to $0.195 \mu\text{g L}^{-1}$, for alcohols from $0.032 \mu\text{g L}^{-1}$ to $0.127 \mu\text{g L}^{-1}$, and for the carboxylic acids from $0.741 \mu\text{g L}^{-1}$ to $104 \mu\text{g L}^{-1}$ (Table 1).
- The reproducibility (RSD%) was obtained by determining the relative standard deviation calculated on the analyses of the samples eight times over a period of two weeks. Reproducibility was measured between 2.2 and 33% for all compounds (Table 1). Reproducibility was low for the carboxylic acids; the extraction conditions were not optimized for these compounds.
- The extraction ratio (E) of the method was evaluated by extracting the same sample five times. The E value was calculated according to Zimmermann et al., by plotting the logarithmical peak areas against the number of extraction and a simplified Eq. (2) [30]. The slope of the linear regression is represented in the equation by the $\log(1 - E)$.

$$\log n_{f,x} = \log(n_{s,0}E) + (x - 1) \log(1 - E) \quad (2)$$

The E value ranged from 1.0% for dodecanoic acid to 77.8% for butan-2-one.

- 850 injections of ACM were made using the same ITEX trap. The results show the reproducibility and stability of the analyses, with a maximum variation of 9.6% between the two extreme results (Fig. 10).

4. Conclusions

This newly developed DHS-VTT technique improves the extraction of volatile compounds from an ACM by a simple and inexpensive modification of the autosampler and by using commercial ITEX hardware. Using the principle of DHS-VTT provides a rapid extraction of target compounds with minimal damage to the

sample and limited artifact formation. Working at reduced pressure increases the evaporation rate of the compounds. Extraction under continuous reduced pressure avoids creating a system in equilibrium, and, thus, extraction remains dynamic. Our results show good repeatability and sensitivity for the majority of the target molecules assessed.

Comparing the results of extraction by DHS-VTT (TTA, TGR, CSIII, and TTA/CSIII), HS-ITEX (TTA) and HS-SPME (DVB/CAR/PDMS), we observe that DHS-VTT shows benefits for both time and sensitivity of extraction for volatile compounds, including group 1, group 2, and group 3 (Table 3). The much larger amounts of compounds extracted with the DHS-VTT method would facilitate more efficient olfactometric analyses. However, further research is necessary to compare how representative the different extraction methods are for odors to validate the developed method for olfactometry profiling. This would also require detailed odor representativeness studies [31,32].

To the authors' knowledge, no other publication has reported on the development of this new DHS-VTT method, which allows for better extraction of target volatiles using shorter extraction times and lower temperatures.

Notes

The authors declare no competing financial interest.

Acknowledgements

We thank Dr. Jacques-Olivier Bosset, Dr. Barbara Guggenbühl, and Dr. Kathryn J Burton for helpful comments on the manuscript.

References

- [1] T. Hüffer, X.L. Osorio, M.A. Jochmann, B. Schilling, T.C. Schmidt, Multi-walled carbon nanotubes as sorptive material for solventless in-tube microextraction (ITEX2)- as factorial design study, *Anal. Bioanal. Chem.* 405 (2013) 8387–8395, <http://dx.doi.org/10.1007/s00216-013-7249-7>.
- [2] M.A. Jochmann, X. Yuan, B. Schilling, T.C. Schmidt, In-tube extraction for enrichment of volatile organic hydrocarbons from aqueous samples, *J. Chromatogr. A* 1179 (2008) 96–105, <http://dx.doi.org/10.1016/j.chroma.2007.11.100>.
- [3] J. Zapata, R. Lopez, P. Herrero, V. Ferreira, Multiple automated headspace in-tube extraction for the accurate analysis of relevant wine aroma compounds and for the estimation of their relative liquid-gas transfer rates, *J. Chromatogr. A* 1266 (2012) 1–9, <http://dx.doi.org/10.1016/j.chroma.2012.10.015>.
- [4] M.T. Suzuki, S. Tsuge, T. Takeuchi, Gas chromatographic estimation of occluded solvents in adhesive tape by periodic introduction method, *Anal. Chem.* 42 (1970) 1705–1708, <http://dx.doi.org/10.1021/ac50160a035>.

- [5] B. Kolb, P. Pospisil, A gas chromatographic assay for quantitative analysis of volatiles in solid materials by discontinuous gas extraction, *Chromatographia* 10 (1977) 705–711, <http://dx.doi.org/10.1007/bf02263080>.
- [6] E.A. Tavss, J. Santalucia, R.S. Robinson, D.L. Carroll, Analysis of flavor absorption into plastic packaging materials using multiple headspace extraction gas chromatography, *J. Chromatogr. A* 438 (1988) 281–289, [http://dx.doi.org/10.1016/S0021-9673\(00\)90259-0](http://dx.doi.org/10.1016/S0021-9673(00)90259-0).
- [7] J. Laaks, M.A. Jochmann, B. Schilling, K. Molt, T.C. Schmidt, In-tube Extraction-GC-MS as a high-capacity enrichment technique for the analysis of alcoholic beverages, *J. Agric. Food Chem.* 62 (2014) 3081–3091, <http://dx.doi.org/10.1021/jf405832u>.
- [8] L. Niu, J. Bao, L. Zhao, Y. Zhang, Odor properties and volatile compounds analysis of *Torreya grandis* aril extracts, *J. Essent. Oil Res.* 23 (2011) 1–6, <http://dx.doi.org/10.1080/10412905.2011.9700461>.
- [9] S.A. Socaci, M. Tofana, C. Socaciu, E. Mudura, C. Muresan, Optimization of ITEX/GC-MS method for determination of indigenous rosemary volatiles, *Bull. UASVM Agric.* 68 (2011) 423–429.
- [10] J. Zapata, L. Mateo-Vivaracho, R.F. Lopez, V. Ferreira, Automated and quantitative headspace in-tube extraction for the accurate determination of highly volatile compounds from wines and beers, *J. Chromatogr. A* 1230 (2012) 1–7, <http://dx.doi.org/10.1016/j.chroma.2012.01.037>.
- [11] S.B. Ampuero, S. Bogdanov, J.O. Bosset, Classification of unifloral honeys with an MS-based electronic nose using different sampling modes: SHS, SPME and INDEX, *Eur. Food Res. Technol.* 218 (2004) 198–207, <http://dx.doi.org/10.1007/s00217-003-0834-9>.
- [12] J. Laaks, M.A. Jochmann, B. Schilling, T.C. Schmidt, Optimization strategies of in-tube extraction (ITEX) methods, *Anal. Bioanal. Chem.* 407 (2015) 6827–6838, <http://dx.doi.org/10.1007/s00216-015-8854-4>.
- [13] I. Rasanen, J. Viinamaki, E. Vuori, I. Ojanpera, Headspace in-tube extraction gas chromatography-mass spectrometry for the analysis of hydroxylic methyl-derivatized and volatile organic compounds in blood and urine, *J. Anal. Toxicol.* 34 (2010) 113–121, <http://dx.doi.org/10.1093/jat/34.3.113>.
- [14] J. Laaks, M.A. Jochmann, B. Schilling, T.C. Schmidt, In-tube extraction of volatile organic compounds from aqueous samples: an economical alternative to purge and trap enrichment, *Anal. Chem.* 82 (2010) 7641–7648, <http://dx.doi.org/10.1021/ac101414t>.
- [15] X.L. Osorio Barajas, T. Huffer, P. Mettig, B. Schilling, M.A. Jochmann, T.C. Schmidt, Investigation of carbon-based nanomaterials as sorbents for headspace in-tube extraction of polycyclic aromatic hydrocarbons, *Anal. Bioanal. Chem.* 409 (2017) 3861–3870, <http://dx.doi.org/10.1007/s00216-017-0331-9>.
- [16] X.L.O. Barajas, M.A. Jochmann, T. Huffer, B. Schilling, T.C. Schmidt, Sorbent material characterization using in-tube extraction needles as inverse gas chromatography column, *J. Sep. Sci.* 40 (2017) 2390–2397, <http://dx.doi.org/10.1002/jssc.201601198>.
- [17] A. Kremser, M.A. Jochmann, T.C. Schmidt, Systematic comparison of static and dynamic headspace sampling techniques for gas chromatography, *Anal. Bioanal. Chem.* 408 (2016) 6567–6579, <http://dx.doi.org/10.1007/s00216-016-9843-y>.
- [18] P.J.L. Nyman, W. Limm, T.H. Begley, S.J. Chirtel, Single-laboratory validation of a method for the determination of select volatile organic compounds in foods by using vacuum distillation with gas chromatography/mass spectrometry, *J. AOAC Int.* 97 (2014) 510–520, <http://dx.doi.org/10.5740/jaoacint.13-294>.
- [19] E. Psillakis, E. Yiantzi, L. Sanchez-Prado, N. Kalogerakis, Vacuum-assisted headspace solid phase microextraction: improved extraction of semivolatiles by non-equilibrium headspace sampling under reduced pressure conditions, *Anal. Chim. Acta* 742 (2012) 30–36, <http://dx.doi.org/10.1016/j.aca.2012.01.019>.
- [20] M.H. Hiatt, Vacuum distillation coupled with gas Chromatography/Mass spectrometry for the analysis of environmental samples, *Anal. Chem.* 67 (1995) 4044–4052, <http://dx.doi.org/10.1021/ac00118a003>.
- [21] M.H. Hiatt, Analyses of fish tissue by vacuum distillation/gas chromatography/ mass spectrometry, *Anal. Chem.* 69 (1997) 1127–1134, <http://dx.doi.org/10.1021/ac960936j>.
- [22] N.P. Brunton, D.A. Cronin, F.J. Monahan, The effects of temperature and pressure on the performance of carboxen/PDMS fibres during solid phase microextraction (SPME) of headspace volatiles from cooked and raw turkey breast, *Flavour Fragr. J.* 16 (2001) 294–302, <http://dx.doi.org/10.1002/ffj.1000>.
- [23] E.K. Yianthi, N. Kalogerakis, E. Psillakis, Vacuum-assisted headspace solid phase microextraction of polycyclic aromatic hydrocarbons in solid samples, *Anal. Chim. Acta* 890 (2015) 108–116, <http://dx.doi.org/10.1016/j.aca.2015.05.047>.
- [24] E. Yiantzi, N. Kalogerakis, E. Psillakis, Design and testing of a new sampler for simplified vacuum-assisted headspace solid-phase microextraction, *Anal. Chim. Acta* 927 (2016) 46–54, <http://dx.doi.org/10.1016/j.aca.2016.05.001>.
- [25] P. Fuchsmann, M.T. Stern, Y.A. Brugger, K. Breme, Olfactometry profiles and quantitation of volatile sulfur compounds of swiss tilsit cheeses, *J. Agric. Food Chem.* 63 (2015) 7511–7521, <http://dx.doi.org/10.1021/acs.jafc.5b02536>.
- [26] D. Canac-Arteaga, C. Viallon, J.-L. Berdagu e, Analytical artifacts caused by the presence of water vapor in the headspace of food products, *Analisis* 28 (2000) 550–556, <http://dx.doi.org/10.1051/analisis:2000170>.
- [27] E. Psillakis, A. Mousouraki, E. Yiantzi, N. Kalogerakis, Effect of Henry's law constant and operating parameters on vacuum-assisted headspace solid phase microextraction, *J. Chromatogr. A* 1244 (2012) 55–60, <http://dx.doi.org/10.1016/j.chroma.2012.05.006>.
- [28] T. Gorecki, J. Pawliszyn, Effect of sample volume on quantitative analysis by solid-phase microextraction. Part 1. Theoretical considerations, *Analyst* 122 (1997) 1079–1086, <http://dx.doi.org/10.1039/a701303e>.
- [29] T.K. Gorecki, A. Khaled, J. Pawliszyn, The effect of sample volume on quantitative analysis by solid phase microextraction. Part 2. Experimental verification, *Analyst* 123 (1998) 2819–2824, <http://dx.doi.org/10.1039/A806788K>.
- [30] T.E. Zimmermann, W.J. Ensinger, T.C. Schmidt, Depletion solid-phase microextraction for the evaluation of fiber-sample partition coefficients of pesticides, *J. Chromatogr. A* 1102 (2006) 51–59, <http://dx.doi.org/10.1016/j.chroma.2005.10.034>.
- [31] C. Murat, K. Gourrat, H. Jerosch, N. Cayot, Analytical comparison and sensory representativity of SAFE, SPME, and Purge and Trap extracts of volatile compounds from pea flour, *Food Chem.* 135 (2012) 913–920, <http://dx.doi.org/10.1016/j.foodchem.2012.06.015>.
- [32] S. Mallia, R. Fernandez-Garcis, J.O. Bosset, Comparison of purge and trap and solid phase microextraction techniques for studying the volatile aroma compounds of three European PDO hard cheeses, *Int. Dairy J.* 15 (2005) 741–758, <http://dx.doi.org/10.1016/j.idairyj.2004.11.007>.